

Single Gear Pumps

單聯齒輪泵

HGP-1A Series



- Pmax/最高壓力: 250bar (3500psi)
- Qmax/吐出量: 0.5cc/rev~7.8cc/rev
- Mounting Type/法蘭型式: SAE 2-bolt/孔式
European/歐洲 & DIN 4-bolt/孔式

How To Order / 型號說明

HGP - 1A - F - 08 - R - X - 2B - 10

1 2 3 4 5 6 7 8

1		5	
Model Hydramax Gear Pump	產品型號 Hydramax 齒輪泵	Rotational Direction *Viewed from shaft side R: Clockwise L: Counter-clockwise	旋轉方向 *由心軸側視之 R: 順時針 L: 逆時針
2		6	
Group 1 Group	尺碼款式 1 款式	Shaft Type X: Straight shaft Y: Spline Shaft	心軸型式 X: 平行鍵 Y: 梅花鍵
3		7	
Mounting F: Flange Type L: Foot Type	固定方式 F: 法蘭型式 L: 腳座型式	Flange Mounting Type 2B: SAE 2-bolt 4BD: DIN 4-bolt 4BE: European 4-bolt	心軸型式 2B: SAE 2孔式 4BD: DIN 4孔式 4BE: 歐洲 4孔式
4		8	
Displacement 0.5: 0.5 cc/rev 0.8: 0.8 cc/rev 1: 1 cc/rev 2: 2 cc/rev 2.6: 2.6 cc/rev	吐出量 0.5: 0.5 cc/rev 0.8: 0.8 cc/rev 1: 1 cc/rev 2: 2 cc/rev 2.6: 2.6 cc/rev	Design Number 10	系列號碼 10

Specifications / 產品規格

Model 產品型號	Displacement Capacity 吐出量 cc/rev	Working Pressure 工作壓力 kg/cm ² (psi)	Max. Pressure 最高壓力 kg/cm ² (psi)	Speed (rpm) 轉速			Weight 重量 kg
				Rate	Max.	Min.	
HGP-1A-F0.5*	0.5	210(3000)	250(3500)	1800	4500	1000	1.0
HGP-1A-F0.8*	0.8	210(3000)	250(3500)	1800	4500	600	1.05
HGP-1A-F1*	1	210(3000)	250(3500)	1800	4500	1000	1.0
HGP-1A-F2*	2	210(3000)	250(3500)	1800	4500	600	1.05
HGP-1A-F2.6*	2.6	210(3000)	250(3500)	1800	4500	600	1.15
HGP-1A-F3*	3	210(3000)	250(3500)	1800	4500	600	1.15
HGP-1A-F4*	4	210(3000)	250(3500)	1800	4000	600	1.18
HGP-1A-F5*	5	210(3000)	250(3500)	1800	3200	600	1.2
HGP-1A-F6*	6	210(3000)	250(3500)	1800	3200	600	1.3
HGP-1A-F8*	7.8	210(3000)	250(3500)	1800	3200	600	1.4

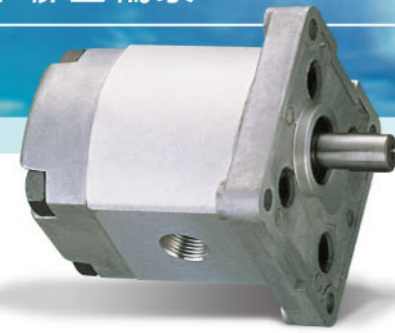

HGP-1A-F*-**-4BE-10 (European / 歐規 4-bolt / 孔式)

Dimensions / 尺寸圖

HGP-1A-F*-**-2B-10 (SAE 2-bolt / 孔式)

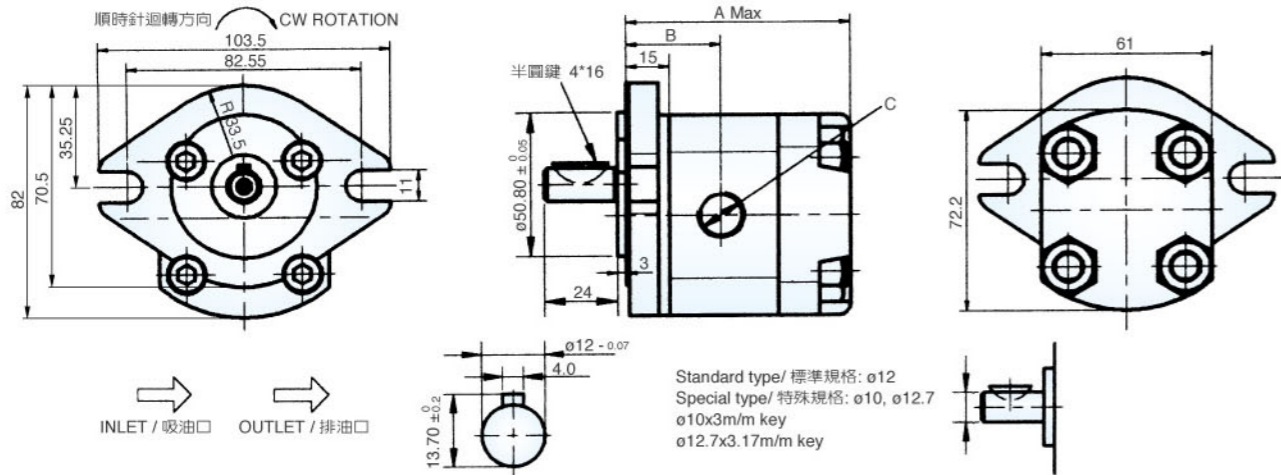

產品型號 / Model	A (m/m)	B (m/m)	C-Inlet	D-Outlet
HGP-1A-F0.8*	67.5	32.5	3/8" PT	3/8" PT
HGP-1A-F1*	69.5	33.5	3/8" PT	3/8" PT
HGP-1A-F2*	72	34.8	3/8" PT	3/8" PT
HGP-1A-F3*	77.5	37.5	3/8" PT	3/8" PT
HGP-1A-F4*	79.5	38.5	3/8" PT	3/8" PT
HGP-1A-F5*	83.5	40.5	3/8" PT	3/8" PT
HGP-1A-F6*	87.5	42.5	3/8" PT	3/8" PT
HGP-1A-F8*	93.5	45.50	1/2" PT	3/8" PT

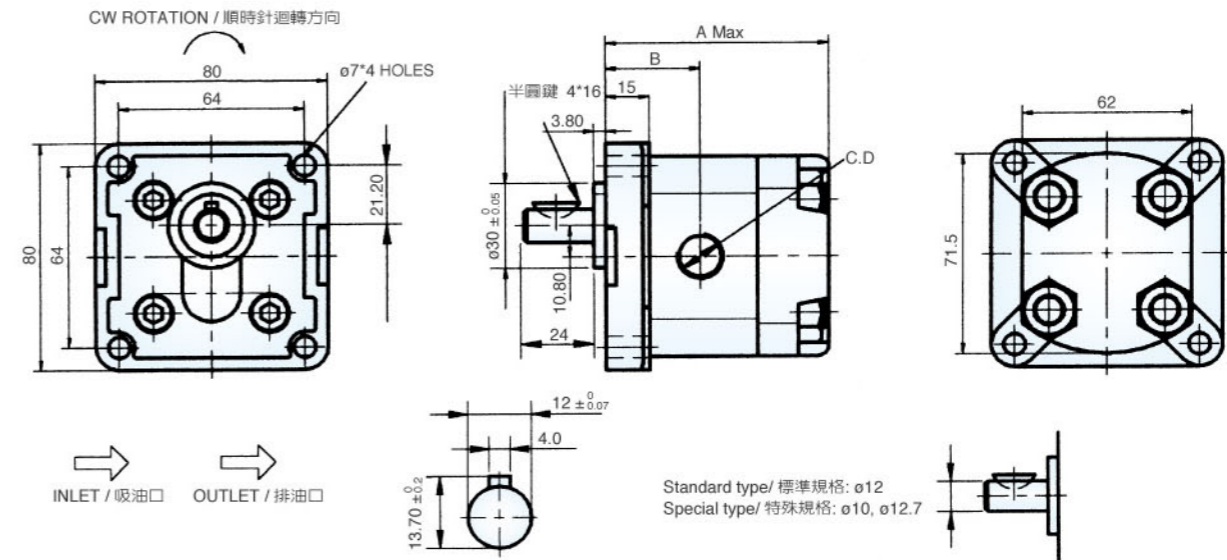

產品型號 / Model	A (m/m)	B (m/m)	C-Inlet	D-Outlet
HGP-1A-F0.8*	75.50	32.5	3/8" PT	3/8" PT
HGP-1A-F1*	77.50	33.5	3/8" PT	3/8" PT
HGP-1A-F2*	80.1	34.8	3/8" PT	3/8" PT
HGP-1A-F3*	85.5	37.5	3/8" PT	3/8" PT
HGP-1A-F4*	87.50	38.5	3/8" PT	3/8" PT
HGP-1A-F5*	91.50	40.5	3/8" PT	3/8" PT
HGP-1A-F6*	95.50	42.5	3/8" PT	3/8" PT
HGP-1A-F8*	101.50	45.50	1/2" PT	3/8" PT

Performance Curves / 性能曲線

Displacement/Power Input/Speed / 吐出量/輸入力/轉速

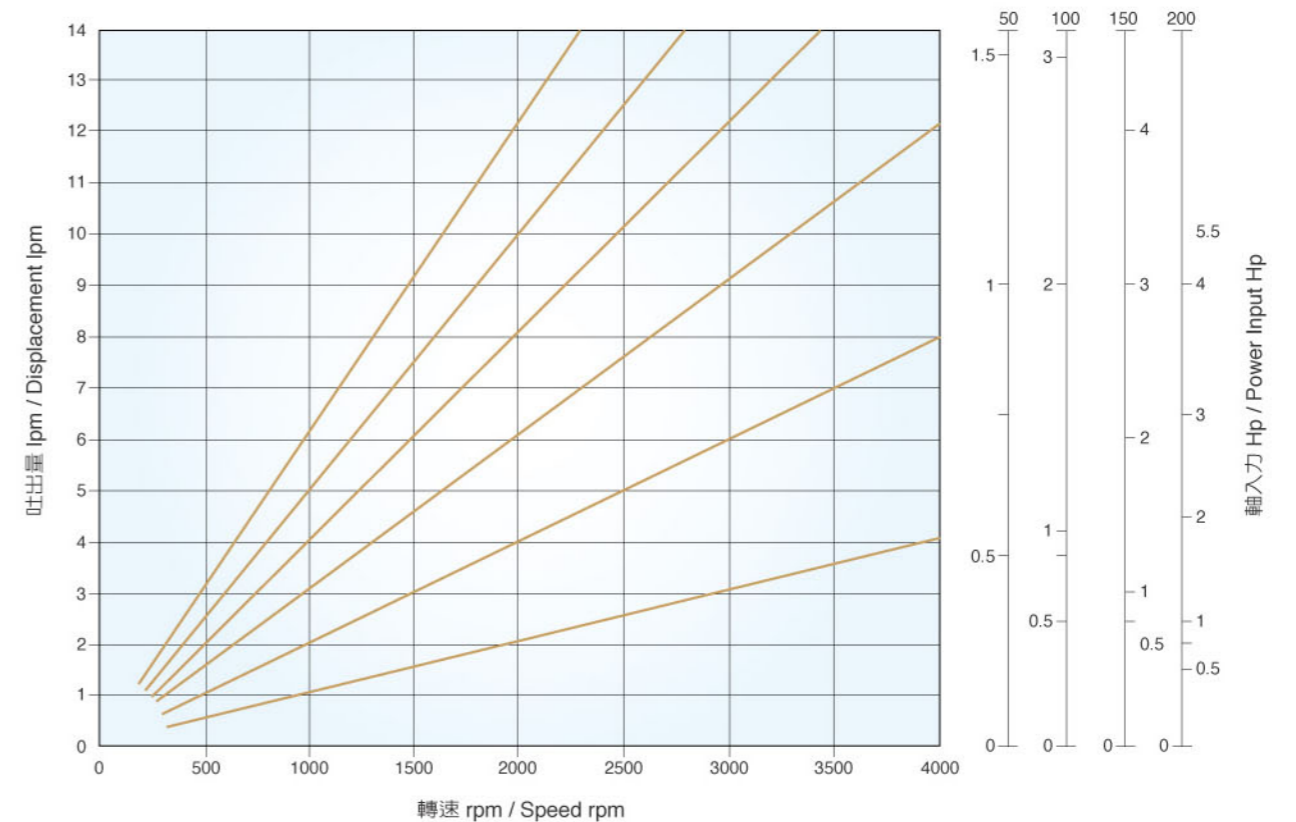

HGP-1A-F*-**-4BD-10 (DIN 4-bolt / 孔式)

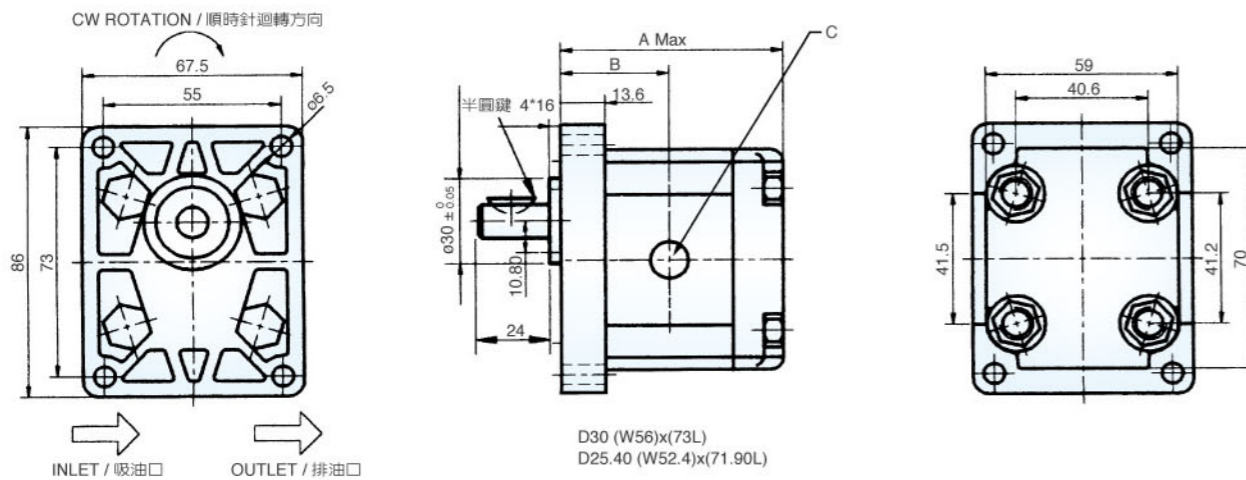

產品型號 / Model	A (m/m)	B (m/m)	C-Inlet	D-Outlet
HGP-1A-F0.8*	67.5	32.5	3/8" PT	3/8" PT
HGP-1A-F1*	69.5	33.5	3/8" PT	3/8" PT
HGP-1A-F2*	72	34.8	3/8" PT	3/8" PT
HGP-1A-F3*	77.5	37.5	3/8" PT	3/8" PT
HGP-1A-F4*	79.5	38.5	3/8" PT	3/8" PT
HGP-1A-F5*	82.5	40.5	3/8" PT	3/8" PT
HGP-1A-F6*	87.5	42.5	3/8" PT	3/8" PT
HGP-1A-F8*	93.5	45.50	1/2" PT	3/8" PT